

## SAMPLE PAPER - 8

### Class 10 - Science

Time Allowed: 3 hours

Maximum Marks: 80

#### General Instructions:

1. This question paper consists of 39 questions in 5 sections.
2. All questions are compulsory. However, an internal choice is provided in some questions. A student is expected to attempt only one of these questions.
3. Section A consists of 20 objective type questions carrying 1 mark each.
4. Section B consists of 6 Very Short questions carrying 02 marks each. Answers to these questions should be in the range of 30 to 50 words.
5. Section C consists of 7 Short Answer type questions carrying 03 marks each. Answers to these questions should be in the range of 50 to 80 words.
6. Section D consists of 3 Long Answer type questions carrying 05 marks each. Answer to these questions should be in the range of 80 to 120 words.
7. Section E consists of 3 source-based/case-based units of assessment of 04 marks each with sub-parts

#### Section A

1. If 20C of charge pass a point in a circuit in 1s, what current is flowing? [1]
  - a) None of these
  - b) 30A
  - c) 20A
  - d) 20C
2. The egg of an animal contains 10 chromosomes, of which one is X-chromosome. How many autosomes would be there in the karyotype of this animal? [1]
  - a) 9
  - b) 18
  - c) 8
  - d) 20
3. The teacher instructed the student to place a healthy potted shoe flower plant in a dark room for 24 hours prior to an experiment on photosynthesis. The purpose of placing it in a dark room is: [1]
  - a) To increase the intake of carbon dioxide
  - b) To denature the enzymes in the leaves
  - c) To activate the chloroplasts in the leaves
  - d) To destarch the leaves
4. **Statement A:** The magnetic field produces a current in a straight wire that has no poles. [1]  
**Statement B:** Like poles of magnets repel each other.  
Which of the following statement is true?
  - a) Statement B is true, A is false
  - b) Statement A is true, B is false



- c) Both the statement A and B are true      d) Both statement A and B are false
5. Although metals form basic oxides, which of the following metals form an amphoteric oxide? [1]
- a) Al      b) Cu  
c) Na      d) Ca
6. Which of the following compounds contain the functional group -OH? [1]
- A. Propane  
B. Propanol  
C. Ethanoic acid  
D. Ethanol
- a) All of these      b) B and D  
c) A and C      d) B and C
7. Two solution A and B were found to have pH values of 6 and 8 respectively. The inference which can be drawn is [1]
- a) the strength of solution B is higher than that of A      b) both are acid solutions  
c) both are basic solutions      d) A is an acid while B is a base
8. Offspring formed as a result of sexual reproduction exhibit more variations because [1]
- a) genetic material comes from two parents of different species      b) genetic material comes from many parents  
c) sexual reproduction is a lengthy process      d) genetic material comes from two parents of the same species
9. Sodium bicarbonate solution is added to dilute ethanoic acid. It is observed that [1]
- a) the mixture becomes light yellow      b) the mixture becomes warm  
c) a solid settles at the bottom      d) a gas evolves
10. State which of the following statement is correct or wrong: [1]
- Statement A:** Estrogen is responsible for bringing changes in appearance seen in boys at the time of puberty.  
**Statement B:** Plasmodium divides into many daughter cells by regeneration.
- a) Both are true      b) A is true and B is false  
c) B is true and A is false      d) Both are false
11. The chromatids are joined to each other by [1]
- a) Centriole      b) Centromere  
c) Spindle      d) Aster
12. What is the maximum power in kilowatts of the appliance that can be connected safely to a 13A, 230V mains socket? [1]
- a) 2.95 kW      b) None of these  
c) 2.99 kW      d) 2.97 kW
13. A ray of light is incident on a glass slab at an angle of incidence of 60 degree. If the angle of refraction be 32.7 degree. What will be refractive index of glass assuming  $\sin 60^\circ = 0.866$  and  $\sin 32.7^\circ = 0.540$ ? [1]



- a) 1.603  
c) 1.327
- b) None of these  
d) 1.540

14. Match the following with the correct response:

[1]

(i) Bauxite	(a) Silver
(ii) Hematite	(b) Iron
(iii) Galena	(c) Aluminium
(iv) Argentite	(d) Lead

- a) (i) - (c), (ii) - (b), (iii) - (d), (iv) - (a)  
c) (i) - (d), (ii) - (a), (iii) - (c), (iv) - (b)
- b) (i) - (c), (ii) - (d), (iii) - (a), (d) - (b)  
d) (i) - (a), (ii) - (c), (iii) - (b), (iv) - (d)

15. Mohit prepared temporary mount of a leaf peel and draw the following diagram. The missing part in the diagram is:

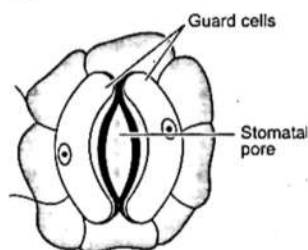

- a) Chloroplasts  
c) Cell wall
- b) Nucleus  
d) Epidermal cells

16. **Statement A:** Semens also contains an enzyme that activates the sperm after ejaculation.

[1]

**Statement B:** The function of stigma is to produce ovules.

- a) Both the statements A and B are true  
c) Statement A is true, B is false
- b) Statement B is true, A is false  
d) Neither statement A nor statement B is true.

17. **Assertion (A):** Magnetic field lines never intersect.

[1]

**Reason (R):** At a particular point magnetic field has only one direction.

- a) Both A and R are true and R is the correct explanation of A.  
c) A is true but R is false.
- b) Both A and R are true but R is not the correct explanation of A.  
d) A is false but R is true.

18. **Assertion(A):** Ammonia solution is an alkali.

[1]

**Reason (R):** Ammonia solution turns blue litmus paper red.

- a) Both A and R are true and R is the correct explanation of A.  
c) A is true but R is false.
- b) Both A and R are true but R is not the correct explanation of A.  
d) A is false but R is true.

19. **Assertion (A):** Phototropism is a directional growth movement.

[1]

**Reason (R):** It occurs in the direction of light.

- a) Both A and R are true and R is the correct explanation of A.
- b) Both A and R are true but R is not the correct explanation of A.



c) A is true but R is false.

d) A is false but R is true.

20. **Assertion (A):** CFCs deplete the ozone layer. [1]

**Reason (R):** CFCs are used as refrigerants and in fire extinguishers.

a) Both A and R are true and R is the correct explanation of A.

b) Both A and R are true but R is not the correct explanation of A.

c) A is true but R is false.

d) A is false but R is true.

#### Section B

21. An organic compound A (molecular formula  $C_2H_4O_2$ ) reacts with Na metal to form a compound B and evolves a gas which burns with a pop sound. Compound A on treatment with an alcohol C in the presence of a little of concentrated sulphuric acid forms a sweet-smelling compound D (molecular formula  $C_3H_6O_2$ ). Compound D on treatment with NaOH solution gives back B and C. Identify A, B, C and D. [2]

OR

Mention four differences between saturated and unsaturated hydrocarbons.

22. Explain reflex arc or reflex path [2]

.OR

What will happen, if you step accidentally on a nail?

23. Why is damage to the ozone layer a cause for concern? What steps are being taken to limit this damage? [2]

24. What is biomass? How is the energy related to it? [2]

25. An object is placed at a distance of 10 cm from a convex mirror of focal length 15 cm. Find the position and nature of the image. [2]

OR

A real image,  $\frac{4}{5}$  size of the object is formed 18 cm from a lens. Calculate focal length of the lens.

26. Draw the electron dot structures for : Propanone [2]

#### Section C

27. Explain the following in terms of gain or loss of oxygen with two examples each: [3]

a. Oxidation

b. Reduction

28. What should be the position of an object with respect to focus of a convex lens of focal length 20cm, so that its real and magnified image is obtained? [3]

29. Answer the following by carefully studying the figure: [3]

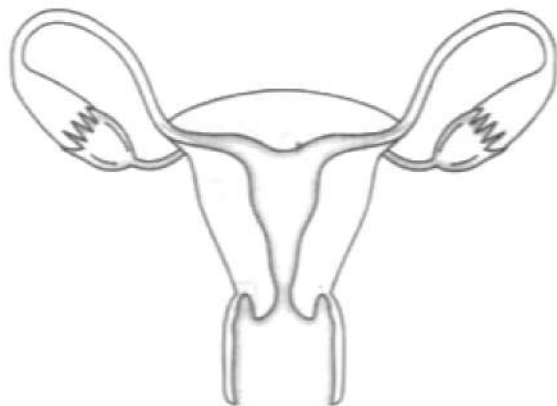

i. Identify the image shown above.

ii. Label in the figure the ovary, oviduct, uterus, vagina.

iii. State the functions of the labeled parts in part b.



OR

An individual may have a good health even when the whole of reproductive system is removed. What then is the function of the reproductive system?

30. When one enters a less lighted room from a place of intense light, he is not able to see anything for sometime, but after sometime the things become somewhat visible. Explain how this happens? [3]
31. A magnesium ribbon is burnt in oxygen to give a white compound X accompanied by emission of light. If the burning ribbon is now placed in an atmosphere of nitrogen, it continues to burn and forms a compound Y. [3]
- (i) Write the chemical formulae of X and Y.
- (ii) Write the balanced chemical equation when X is dissolved in water.
32. Show how man has been able to produce crop plants by selective breeding. [3]

OR

In a monohybrid cross, pink coloured flowers are dominant over white coloured flowers. If parent plants belong to pure breeding dominant trait and pure breeding recessive trait, what will be the phenotype or morphological feature of  $F_1$ -generation? If  $F_1$  plants are self-fertilised, what would be the phenotypic ratio or how many dominant and recessive traits will be produced in the progeny? Explain with an illustration.

33. A student sitting at the back of the classroom cannot read clearly the letters written on the backboard. What advice will a doctor give to her? [5]

#### Section D

34. How is copper obtained from its ore ( $Cu_2S$ )? Write only the chemical equations. How is copper thus obtained refined? Name and explain the process alongwith a labelled diagram. [5]

OR

An ore on treatment with dilute hydrochloric acid gives a smell like that of rotten eggs. What type of ore is this? How can it be concentrated? How can the metal be obtained from the concentrated ore?

35. What are the common features between all the respiratory organs? Explain the mechanism of gaseous exchange between tissues and blood. [5]

OR

Explain how deoxygenated blood travels from body to lung for purification. Draw well-labelled diagram in support of your answer.

36. What is the necessity of earthing an electric appliance? [5]

#### Section E

37. **Read the text carefully and answer the questions:** [4]

If two or more resistances are connected in such a way that the same potential difference gets applied to each of them, then they are said to be connected in parallel.

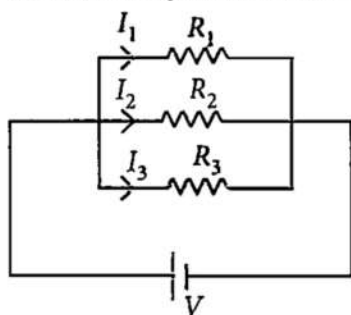

The current flowing through the two resistances in parallel is, however, not the same. When we have two or more resistances joined in parallel to one another, then the same current gets additional paths to flow and the overall resistance decreases.

- (i) Three resistances,  $2\ \Omega$ ,  $6\ \Omega$  and  $8\ \Omega$  are connected in parallel, then what will be the equivalent resistance?  
(ii) A wire of resistance  $12\ \Omega$  is cut into three equal pieces and then twisted their ends together, then what will be the equivalent resistance?

OR

Three resistances are connected as shown. Calculate the equivalent resistance between A and B?

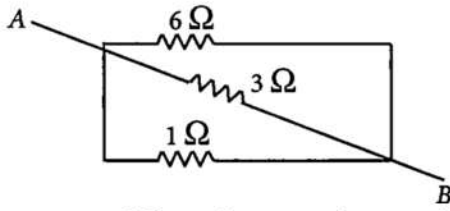

38. Read the text carefully and answer the questions:

[4]

Following questions are based on the two tables given below. Study these tables related to blood sugar levels:

**Table A (Blood glucose chart)**

	Mean Blood Glucose Level (mg/dL)
Doctor's advice needed	380
	350
	315
	280
	250
	215
Good	180
	150
Excellent	115
	80
	50

**Table B (Blood Report of Patient X and Y)**

Time of check	Blood Glucose ranges (mg/dL)	
	Patient X	Patient Y
Before breakfast (Fasting)	<100	70-130
Before lunch, supper and snack	<110	70-130
Two hours after meals	<140	<180
Bedtime	<120	90-15

- (i) Refer to Table B showing the blood report of the levels of glucose of patients X and Y. Infer the disease which can be diagnosed from the given data.  
(ii) Identify the hormone whose level in the blood is responsible for the above disease.  
(iii) High/low sugar and a low/high-fat diet What would you recommend to the affected patient?

OR

Refer to Table A and suggest the value of the mean blood glucose level beyond which doctor's advice is necessary.

39. **Read the text carefully and answer the questions:**

[4]

Salt of a strong acid and strong base is neutral with a pH value of 7. NaCl common salt is formed by a combination of hydrochloride and sodium hydroxide solution. This is the salt that is used in food. Some salt is called rock salt, bed of rock salt was formed when seas of bygone ages dried up. The common salt thus obtained is an important raw material for various materials of daily use, such as sodium hydroxide, baking soda, washing soda, and bleaching powder.

- (i) If given acids are phosphoric acid, carbonic acid, hydrochloric acid and sulphuric acid, then which acid does not form an acidic salt?
- (ii) What is the formula of baking soda?
- (iii) Name the substance which on treatment with chlorine to obtain bleaching powder.

**OR**

Which salt is used for removing the permanent hardness of water?



**Solution**  
**SAMPLE PAPER - 8**  
**Class 10 - Science**  
**Section A**

1. (c) 20A

**Explanation:** Given,

Charge moved,  $Q = 20C$

Time taken,  $t = 1s$

To find,

Current,  $I = ?$

We know that the current is calculated as follows:

$$I = \frac{Q}{t}$$

Substituting the values, we get

$$I = \frac{20}{1} = 20A$$

Therefore, 20A current is required to move a charge of 20C in 1s time.

2. (b) 18

**Explanation:** Karyotype is the number and appearance of chromosomes in a nucleus of somatic cell. Somatic cells are diploid cells which make up the body. They have two sets of chromosomes. So, if an egg cell (gamete cell) which is a haploid cell (with single set of chromosomes) has 10 chromosomes, then number of chromosomes present in a somatic cell will be 20 chromosomes. As egg cells are produced by female body, then among 20 chromosomes, two X chromosomes will be sex chromosomes. So, karyotype of that animal will be showing 18 autosomes.

3. (d) To destarch the leaves

**Explanation:** To destarch the leaves

4. (c) Both the statement A and B are true

**Explanation:**

A. The magnetic field of a straight conductor is concentric around the conductor, so the field lines don't seem to start or end anywhere, so there are no poles.

B. When two magnets are placed with their like poles facing each other, the lines of force are in opposite directions, and hence like poles repel each other.

5. (a) Al

**Explanation:** Al (aluminium) forms amphoteric oxides. An amphoteric oxide acts both as an acid as well as a base.

6. (b) B and D

**Explanation:** Ethanol and propanol are alcohols and contain the functional group -OH. Ethanol is  $C_2H_5OH$  and propanol is  $C_3H_7OH$ . Ethanoic acid contains the carboxylic group (-COOH).

7. (d) A is an acid while B is a base

**Explanation:** The pH of 7 is neutral, pH less than 7 is acidic and pH greater than 7 is basic. So A is an acid because acids have  $pH < 7$ . 'B' is a base because bases have  $pH > 7$ .

8. (d) genetic material comes from two parents of the same species

**Explanation:** Sexual reproduction involves two parents of the same species. Thus, both of them contribute to the genetic material of the offspring and bring about the variations.

9. (d) a gas evolves

**Explanation:** Sodium bicarbonate reacts with acetic acid to form water, carbon dioxide and sodium acetate. Carbon dioxide gas is evolved.

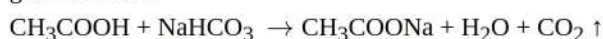

10. (d) Both are false

**Explanation:** Estrogen is the primary female sex hormone. It is responsible for the development and regulation of the female reproductive system and secondary sex characteristics.

Plasmodium reproduces by binary fission and not by regeneration.



11. (b) Centromere

**Explanation:** A sister chromatid refers to either of the two identical copies (chromatids) formed by the replication of a single chromosome, with both copies joined together by a common centromere. In other words, a sister chromatid may also be said to be 'one-half' of the duplicated chromosome. A full set of sister chromatids is created during the synthesis (S) phase of interphase, when all the chromosomes in a cell are replicated. The two sister chromatids are separated from each other into two different cells during mitosis or during the second division of meiosis.

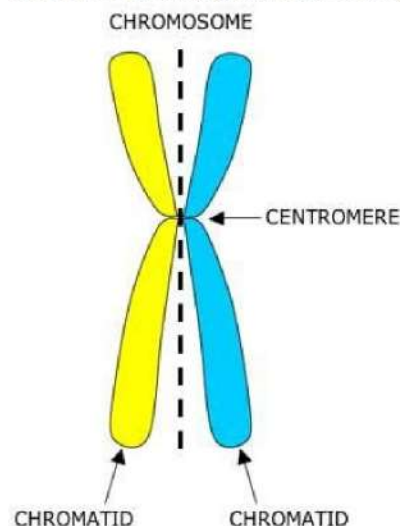

12. (c) 2.99 kW

**Explanation:** Given,

$$I = 13 \text{ amp}$$

$$V = 230 \text{ V}$$

$$P = VI$$

$$P = 2.99 \text{ kW}$$

13. (a) 1.603

**Explanation:** According to Snell's law, the ratio of sine of angle of incidence to the sine of angle of refraction is equal to the constant for a given pair of media.

$$\text{Refractive index} = \frac{(\text{sine of angle of incidence})}{(\text{sine of angle of refraction})}$$

Given,

$$\text{Angle of incidence} = 60 \text{ degree}$$

$$\text{Angle of refraction} = 32.4 \text{ degree}$$

$$\text{Refractive index} = \frac{(\sin 60)}{(\sin 32.4)}$$

$$\text{Refractive index} = 1.603$$

14. (b) (i) - (c), (ii) - (d), (iii) - (a), (d) - (b)

**Explanation:** (i) - (c), (ii) - (d), (iii) - (a), (d) - (b)

15. (a) Chloroplasts

**Explanation:** Chloroplasts

16. (c) Statement A is true, B is false

**Explanation:** Stigma acts as a landing zone for the pollen grains. Mostly stigmas are waxy and sticky.

17. (a) Both A and R are true and R is the correct explanation of A.

**Explanation:** Both A and R are true and R is the correct explanation of A.

18. (c) A is true but R is false.

**Explanation:** A is true but R is false.

Ammonia gas, which is alkaline, turn the red litmus paper blue.

19. (a) Both A and R are true and R is the correct explanation of A.

**Explanation:** Phototropism is the movement or bending of light towards light. Hence, it is known as the directional growth movement.



20. (a) Both A and R are true and R is the correct explanation of A.

**Explanation:** The ozone layer is getting depleted at the higher levels of the atmosphere due to the effect of chlorofluorocarbons (CFCs) which are used as refrigerants and in fire extinguishers.

### Section B

21. A is ethanoic acid,  $\text{CH}_3\text{COOH}$

B is sodium ethanoate,  $\text{CH}_3\text{COONa}$

C is methanol,  $\text{CH}_3\text{OH}$

D is methylethanoate,  $\text{CH}_3\text{COOCH}_3$

OR

Difference between saturated and unsaturated hydrocarbons:

Saturated Hydrocarbons	Unsaturated Hydrocarbons
Only single bond is present in between carbon-carbon atoms.	Double or triple bond is present in between carbon-carbon atoms.
Substitution reaction occurs.	Addition reaction occurs.
They burn with blue flame.	They burn with sooty flame.
These are Less reactive.	These are Highly reactive.

22. If we step accidentally on a nail, the foot is withdrawn immediately. It is due to reflex action or spinal reflex. In such case the stimulus of a pointed object like nail is carried to the spinal cord by the sensory (afferent) nerve fibres to the grey matter of spinal cord through dorsal root. Now after the interpretation, the stimulus is transmitted to motor nerve fibres at the synapse. The motor (efferent) impulse is carried by motor nerve fibre through ventral root to the effector organ and response is made. In this case it is in the form of withdrawal of foot by the contraction of voluntary muscles. They behave involuntarily during reflex action.

23. Ozone layer acts as a protective shield against the harmful Ultraviolet rays of the sun. Depletion of ozone layer leads to exposure to Ultraviolet rays & due to this the incidences of cancer, cataract are on rise. Also the uv rays damage the immune system of human beings.

In 1987, United Nations Environment Programme (UNEP) succeeded in forging an agreement between nations to freeze chlorofluorocarbons (CFCs) production to 1986 levels. CFCs are the main cause of ozone layer depletion.

24. The amount of organic matter present in an organism is called biomass. Biomass is living matter in any organism. Truly speaking, biomass represents the quantity of living tissue as energy available in the form of food for organisms of next trophic level.

25.  $u = -10$  cm [ $u$  is always negative];  $f = 15$  cm [convex mirror]  $v = ?$

$$\text{Using } \frac{1}{f} = \frac{1}{v} + \frac{1}{u}, \text{ we have } \frac{1}{v} = \frac{1}{f} - \frac{1}{u} = \frac{1}{15} - \frac{1}{-10} = \frac{1}{15} + \frac{1}{10} = \frac{2+3}{30} = \frac{5}{30} = \frac{1}{6}$$

So  $v = 6$  cm behind the mirror or towards left of the mirror. Image is virtual and erect.

OR

Since the image is real and diminished, the lens must be convex and the object must be placed beyond  $2F$ .

Given:

$$v = +18 \text{ cm}$$

$$\frac{h'}{h} = \frac{-4}{5} \dots [m = \frac{h'}{h} \text{ is negative for real image}]$$

$$f = ?$$

$$\text{We have, } m = \frac{h'}{h} = \frac{v}{u}$$

$$\frac{v}{u} = \frac{-4}{5}$$

$$\text{and } 4u = -5 \times 18 \text{ cm}$$

$$\text{Therefore, } u = -22.5 \text{ cm}$$

Also focal length is given by

$$\frac{1}{f} = \frac{1}{v} - \frac{1}{u}$$

$$\frac{1}{18} - \frac{1}{-22.5} = \frac{1}{18} + \frac{1}{22.5}$$

$$= \frac{9}{90}$$

$$\text{Therefore, } f = 10 \text{ cm}$$

26. Propanone :

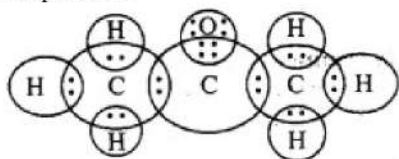

**Section C**

27. Oxidation- Addition of oxygen or removal of hydrogen in a chemical reaction is called oxidation reaction. For example:

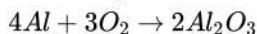
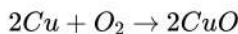

Reduction- Addition of hydrogen or removal of oxygen in a chemical reaction is called reduction reaction. For example:

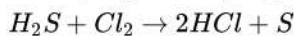

28. Given focal length  $f$  of lens 20 cm

To obtain real and magnified image, the object should be placed between  $F_1$  and  $2F_1$ , So the range will be from 20 cm to 40 cm of convex lens.

29. i. The figure represents the female reproductive system.

ii. The figure with labelled part is as shown.

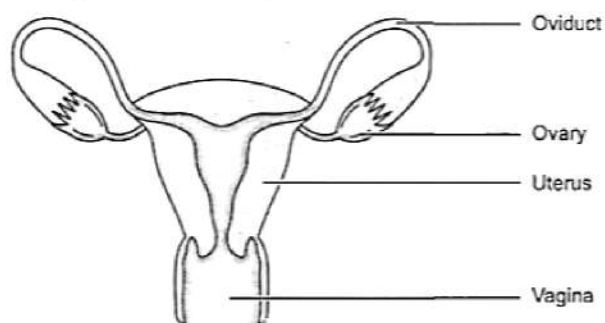

iii. The ovary is the female primary sex organ that produces ova or eggs. They secrete female hormones oestrogen and progesterone. The oviduct receives the egg released from the ovum and it is the site of fertilisation. The uterus is a muscular organ where implantation of zygote occurs and it takes care of the developing embryo. The vagina is a muscular tube-like structure which receives the sperms and through which the baby is delivered.

OR

The main function of the reproductive system is to produce the gametes for the sexual reproduction. Reproductive system is not necessary for the survival of the individual. So even if reproductive system is fully removed, the persons may have a good health. That is why the persons who are sterile cannot reproduce but can survive.

30. When we are in bright sunlight the aperture of the pupil would be small to regulate the amount of light entering the eye preventing glare, discomfort and damage to eyes. As we enter a dark room less amount of light would enter our eyes due to small size of pupil, and we won't be able to see objects clearly. It takes some time to regulate the size of the pupil through iris. Hence, it requires some time to see things.

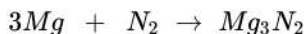
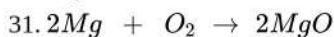

(i)  $X$  is  $MgO$ ;  $Y$  is  $Mg_3N_2$

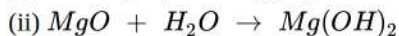

32. Crop plants produced by selective breeding

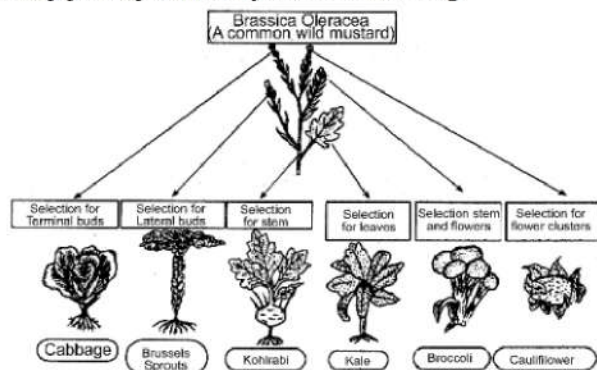

OR

Let the dominant trait be represented by PP.

Let the recessive trait be represented by pp.

Parents PP × pp

F<sub>1</sub>-generation (p<sub>p</sub>) (p<sub>p</sub>) (p<sub>p</sub>) (p<sub>p</sub>) i.e. all pink colour flowers, but hybrid. i.e. none are pure homozygous all the progeny has heterozygous combination, but since, pink is dominant over white, all are pink.

F<sub>2</sub>-generation when self-fertilised (p<sub>p</sub>) × (p<sub>p</sub>)

F<sub>2</sub>-generation gives (PP) (Pp) (Pp) (pp)

Ratio 3 pink colour flowers : 1 white colour flower.

33. This student is unable to see far off objects. This means that the student is suffering from myopia. Doctor will prescribe a concave lens of suitable focal length.

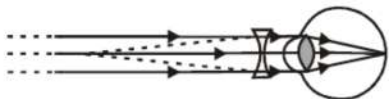

Correction for myopia

#### Section D

34. Copper is obtained from its ore Copper glance (Cu<sub>2</sub>S) in two steps:

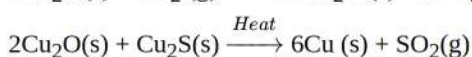
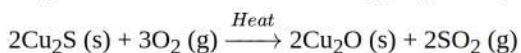

The Copper thus obtained is refined by the process called "Electrolytic Refining". In this, the impure copper is made anode by connecting to the positive terminal of the battery and a thin plate of pure copper is made cathode by connecting to the negative terminal of the battery. The copper sulphate(acidified) solution is taken in the tank which acts as an electrolyte. When an electric current is passed through the solution, the pure copper from the anode passes into the solution and an equivalent amount of Cu<sup>+</sup> ions from the solution are deposited on the cathode as pure copper. Impure copper usually contains the impurities (Fe, Ag, Au) which collects below the anode as "Anode mud".

At cathode : Cu<sup>2+</sup>(aq) + 2e<sup>-</sup> → Cu(s)

At anode : Cu(s) → Cu<sup>2+</sup>(aq) + 2e<sup>-</sup>

The diagram shown below is of electrolytic refining of copper

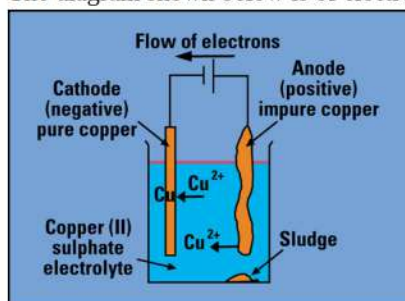

OR

The gas which smells like that of rotten eggs is H<sub>2</sub>S. Hence, the ore is a sulphide ore. It is concentrated by froth-floatation process. The metal is obtained from the concentrated ore in the following two steps:

- i. Roasting: Heating the ore strongly in the presence of air. The metal sulphide is converted into metal oxide along with evolution of sulphur dioxide gas.



- ii. Reduction with carbon: On heating the metal oxide with carbon, it is reduced to free metal.

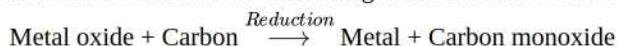

35. Common features between all the respiratory organs are:

- (i) All the respiratory organs have large surface areas to get enough oxygen.
- (ii) All the respiratory organs are thin-walled for easy diffusion of gases and substances.
- (iii) All the respiratory organs (like skin, lungs, gills) have a rich supply of blood for transporting respiratory gases.

The mechanism of gaseous exchange between tissues and blood is as follows:

- (i) The blood reaching the tissues has higher concentration of oxygen than in the cells so it gets diffused into the cells.
- (ii) The carbon dioxide, which is formed in the cells, gets accumulated in higher concentration as compared in the blood, so it

easily diffuses into the blood.

(iii) The blood with takes this gas to the lungs, from where it is expelled out during exhalation.

OR

The deoxygenated blood is collected from the body tissues through the veins which further combine to form vena cava. This vena cava pours deoxygenated blood collected from the body tissues into the right auricle of the heart. From the right auricle, it goes to the right ventricle and from here the blood is pumped into the pulmonary artery which takes the deoxygenated blood from the heart to the lungs. In the alveoli of the lungs, the blood is oxygenated. This oxygenated blood is pumped into the pulmonary veins which pour the blood into the left auricle. From here the oxygenated blood is poured into the left ventricle. The left ventricle pushes the blood into the aorta which pumps the oxygenated blood into the body tissues and supplies oxygen through the tissues for various body functions.

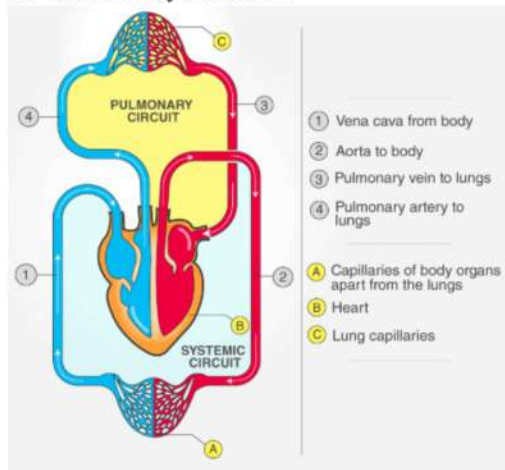
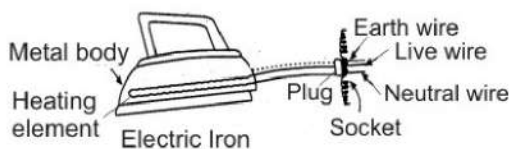

Figure: The double circulation of blood

36. In order to work an electric apparatus, we require two wires, one live wire and the other neutral. Due to wear and tear or due to excessive heating, sometimes live wire touches the body of the apparatus. Thus we get shock when we incidentally touch the apparatus. To avoid the risk of electric shock, the metal body of the electric appliance is earthed i.e. a wire is connected to the cover of vessel on one side and to the earth point in three pin plug. The one end of the earth point is buried deep in the earth. Earth wire is usually given green or green-yellow colour, the live wire is usually red or brown while black or light blue wire acts a neutral wire.



### Section E

37. Read the text carefully and answer the questions:

If two or more resistances are connected in such a way that the same potential difference gets applied to each of them, then they are said to be connected in parallel.

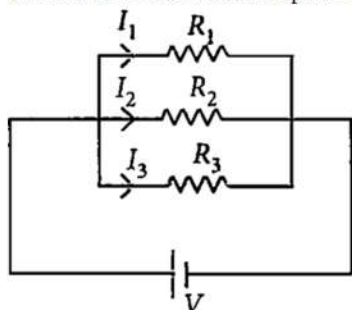

The current flowing through the two resistances in parallel is, however, not the same. When we have two or more resistances joined in parallel to one another, then the same current gets additional paths to flow and the overall resistance decreases.

(i) The equivalent resistance in the parallel combination is lesser than the least value of the individual resistance.

The equivalent resistance of parallel combinations

$$\frac{1}{R_p} = \frac{1}{2} + \frac{1}{4} + \frac{1}{8}$$

$$\Rightarrow R_p = \frac{8}{7} \Omega$$

Thus equivalent resistance is less than  $2\Omega$ .

(ii) Resistance of each piece =  $\frac{12}{3} = 4\Omega$

$$\frac{1}{R_p} = \frac{1}{4} + \frac{1}{4} + \frac{1}{4} = \frac{3}{4} \Rightarrow R_p = \frac{4}{3}\Omega$$

OR

All the three resistors are in parallel.

$$\therefore \frac{1}{R_p} = \frac{1}{6} + \frac{1}{3} + \frac{1}{1} = \frac{1+2+6}{6} = \frac{9}{6} \Rightarrow R_p = \frac{6}{9} = \frac{2}{3}\Omega$$

38. Read the text carefully and answer the questions:

Following questions are based on the two tables given below. Study these tables related to blood sugar levels:

**Table A (Blood glucose chart)**

	Mean Blood Glucose Level (mg/dL)
Doctor's advice needed	380
	350
	315
	280
	250
	215
Good	180
	150
Excellent	115
	80
	50

**Table B (Blood Report of Patient X and Y)**

Time of check	Blood Glucose ranges (mg/dL)	
	Patient X	Patient Y
Before breakfast (Fasting)	<100	70-130
Before lunch, supper and snack	<110	70-130
Two hours after meals	<140	<180
Bedtime	<120	90-15

(i) Diabetes, Diabetes is caused due to less or no secretion of hormone insulin by pancreas.

(ii) Insulin level in the blood is responsible for the given disease.

(iii) Low sugar high fibre diet

OR

> 180mg/dL.

39. Read the text carefully and answer the questions:

Salt of a strong acid and strong base is neutral with a pH value of 7. NaCl common salt is formed by a combination of hydrochloride and sodium hydroxide solution. This is the salt that is used in food. Some salt is called rock salt, bed of rock salt was formed when seas of bygone ages dried up. The common salt thus obtained is an important raw material for various materials of daily use, such as sodium hydroxide, baking soda, washing soda, and bleaching powder.

(i) Carbonic acid does not form an acidic salt.

(ii) Sodium bicarbonate, commonly known as baking soda or bicarbonate of soda, is a chemical compound with the formula  $\text{NaHCO}_3$ .

(iii)  $\text{Ca}(\text{OH})_2$  treatment with chlorine to obtain bleaching powder.



OR

Washing soda is used for removing the permanent hardness of the water.